



107 Georges River Road Jannali, NSW

 2
  1
  2

Opportunity Knocks!

This property offers an ideal investment opportunity for either a first home buyer or investor. With a versatile floor plan you could easily convert it from a 2 bedroom to a 3 bedroom and the location will provide excellent capital growth for the future.

You could do a number of things with this property and being on a level block a duplex opportunity is possible (STA). Alternatively you could rent it out as is or move in and start adding value.

Features include:

- 682.91sqm level block
- Original 2/3 bedroom cottage
- High Ceilings
- Enormous garage/ workshop
- Plenty of off street parking

This property is being offered exclusively to our database at this stage and at this price we expect to have a lot of interest. If you are in a position to buy please call to arrange

Type : House
Sold Date : Monday, 21st January 2019

Derin Hill
 0295452220

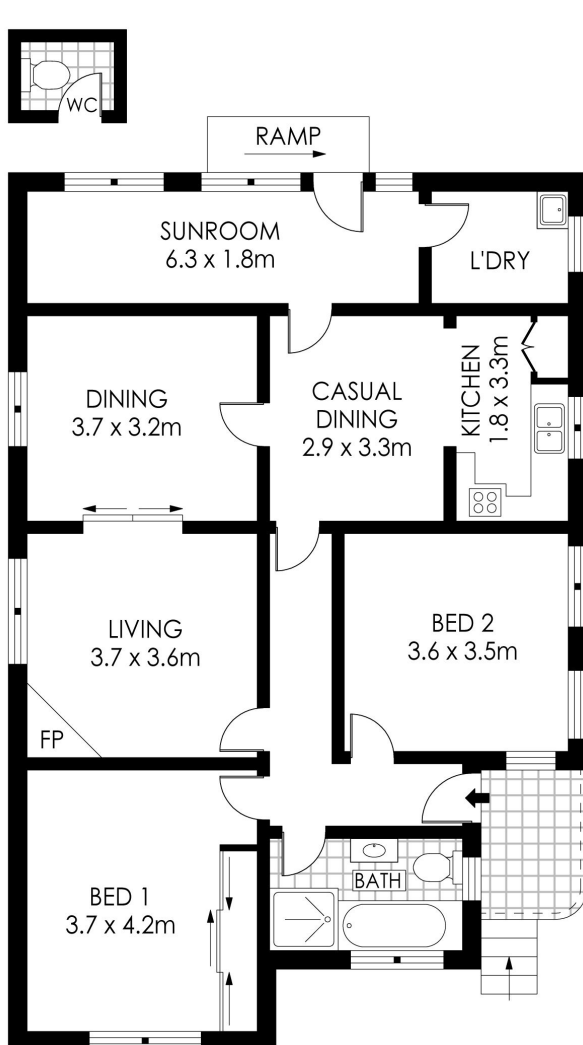

GROUND FLOOR

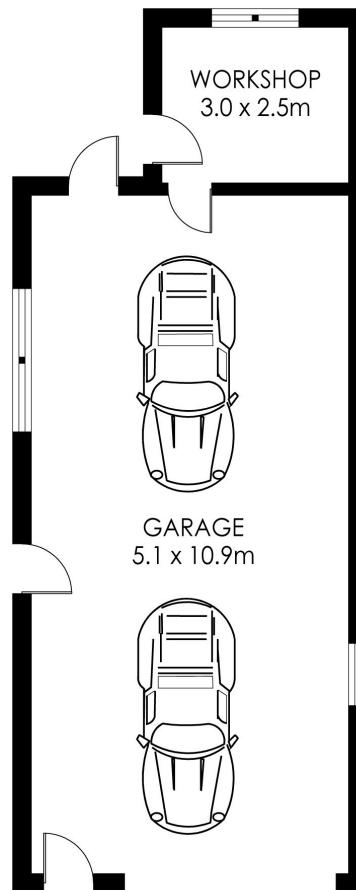

GROUND FLOOR



PLANS SHOWN ONLY INDICATIVE OF LAYOUT. DIMENSIONS ARE APPROXIMATE.
 Floor plans by www.remaustralia.com
 Ref. No: 13084



Hill & Viteri
 PROPERTY

9545 2220
hillandviteriproperty.com.au

107 GEORGES RIVER ROAD

JANNALI

107 Georges River Road, Jannali NSW