



23 Gorada Avenue Kirrawee, NSW

4 3 2

## Superb Family Home

Positioned in a quiet family-friendly cul-de-sac with commanding views of the surrounding district you will enjoy the private aspect this property offers. Ideally suited to families both young and grown.

Features include:

- Entertainer's Kitchen with stainless steel appliances
- 4 generous bedrooms
- Main bedroom with walk-in robe & ensuite
- 3 bathrooms including 2 ensuites
- Parents Retreat with balcony
- Air-conditioning
- Quality fixtures and fittings throughout
- Covered outdoor entertaining area
- Double garage or outdoor rumpus
- Plenty of off-street parking

Located within walking distance of either Kirrawee or Gymea stations and falling within th

## Auction

**Type** : House  
**Sold Date** : Wednesday, 13th November 2019  
**Land** : 670 m2

**Derin Hill**  
 0295452220

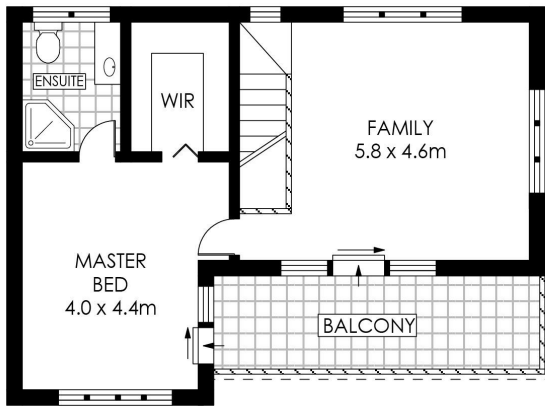

**LEVEL ONE**

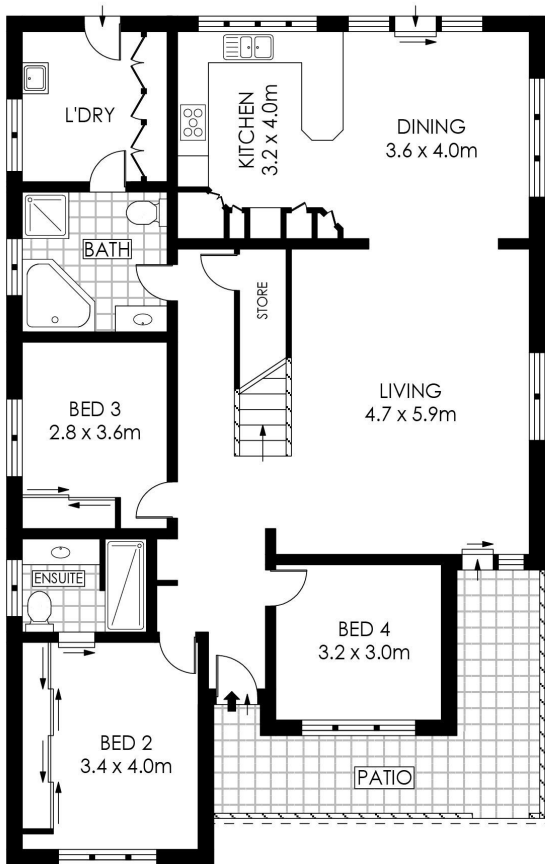

**GROUND LEVEL**

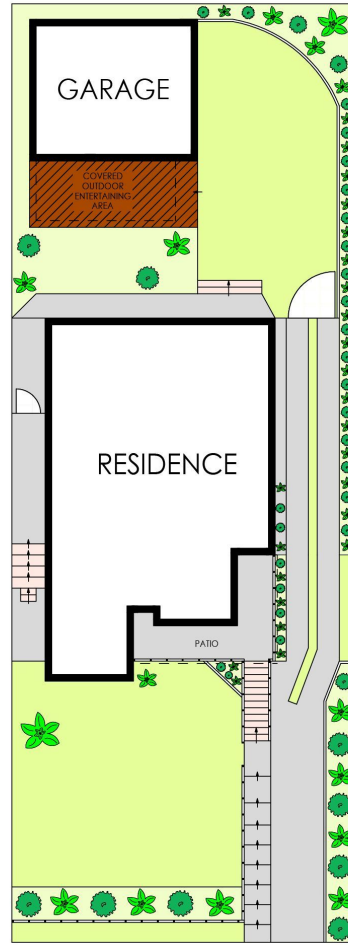

**SITE PLAN**  
(NOT TO SCALE)

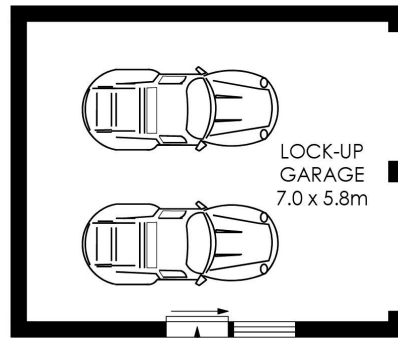

**GROUND LEVEL**



PLANS SHOWN ONLY INDICATIVE OF LAYOUT. DIMENSIONS ARE APPROXIMATE.  
Floor plans by [www.remaustralia.com](http://www.remaustralia.com)  
Ref. No: 13703

Hill & Viteri  
PROPERTY

9545 2220  
[hillandviteriproperty.com.au](http://hillandviteriproperty.com.au)

23 GORADA AVENUE

KIRRAWEE

**23 Gorada Avenue, Kirrawee NSW**